



**VE Commodore/HSV UTE**  
**2006-2009**  
**PWM Fuel System Controller**





## Important! Must Read First

Congratulations on the purchase of a KPM Fuel System for your [2006-onwards Holden/HSV V8 Commodore Ute](#).

To ensure your fuel system is fitted correctly and operates perfectly and reliably, we advise that this kit is fitted by a KPM Fuel Systems Dealer workshop.

If you are unable to access a KPM Fuel Systems dealer, we [strongly](#) recommend a professional and experienced fully qualified technician to install your new fuel system.

### **REFER TO VE-VF TECH SHEET FOR CALIBRATION INSTRUCTIONS**

Ask your qualified installer to contact KPM Fuel Systems on any aspect unclear in the instructions provided.

Email: [enquiries@kpmfuelsystems.com.au](mailto:enquiries@kpmfuelsystems.com.au)

As a wide variety of skills, procedures, special tools, and workshop equipment is needed to install this kit:

- KPM will take NO responsibility or give NO guarantees on the operation of this product for fitment not carried out by a KPM Fuel Systems dealer or experienced qualified technician.
- KPM will take NO responsibility or give NO guarantees on the operation of this product due to not fitting this kit exactly as per the instructions provided.
- Ensure correct workshop safety procedures are carried out in fitment of this kit.
- Please read **ALL** instructions before commencing fitment

## Guarantee

On satisfaction that [ALL](#) instructions have been followed as per this document KPM will warrant this KPM Fuel System against any defects or faults for 12 months from the date of purchase.



## Operation and Functions

The KPM Pulse Width Modulated (PWM) Fuel System Controller has been specifically designed to support up to 80 amps of continuous current draw.

This gives it the capability of running up to 4x high flow motorsport fuel pumps simultaneously and continuously.

The controller is programmed to run the fuel system at a pre-determined fuel pressure. The fuel pumps will only be run at the duty cycle required and when required. This ensures less current draw, which means less heat, improved reliability and precise tune-ability.

With this amount of control over fuel flow, we now have the ability to support extreme horsepower with OE level functionality.

The KPM Fuel System Controller is fully programmed from factory to perfectly suit all vehicle models and the many combinations of fuel delivery required.

The KPM Fuel System Controller has the following functions:

- 80-amp continuous current support
- Fully programmable to control up to 4 fuel pumps by means of one or all of the following inputs:
  - Fuel pressure, MAP, MAF, Throttle position. \*
- Fully programmable OE factory PWM input, piggy back control
- Fully programmable pump output and pump staging\*
- Fully programmable system pressure settings\*
- Multiple options for safety settings and pump control\*
- Multiple gauge and warning light outputs\*
- Advanced low temperature electronic circuits for robust motorsport and long-term reliability
- Supplied with EMI shielded high amperage wiring and connector kit to block out interference with other vehicle electronic modules and devices.
- LED on controller for visual system pass and fault code readout.
- Fully modular fitment to all KPM Fuel Systems

[\\*To re-program this function please contact KPM Fuel Systems.](#)

The KPM PWM Fuel System Controller will be supplied pre-programmed to exactly suit the model of your vehicle and the level of KPM fuel system purchased.

There is nothing to do, just follow the wiring instructions, plug in the connectors and start



the car. Simple! The controller will do the rest.

## **Vehicle and Fuel System Specific Operation and Function**

### VE Commodore/HSV 2006-2009

Early model (2006-2009) VE Commodores/HSV models were not fitted with a factory FSCM (Fuel System Control Module). This means that the KPM fuel controller requires an alternative input signal for pump control.

KPM has supplied a fuel pressure sensor kit required to give the KPM controller the fuel pressure input signal it needs to control the fuel pump/s.

Fuel pressure input is monitored according to engine load and therefore fuel demand. A calculated duty cycle is then delivered to the primary and secondary modules to ensure that a pre-programmed 400 kPa fuel system pressure is maintained at all times and at all loads.

#### **KPM1500 – Primary Module only**

Primary module fuel pumps are always running and duty cycle input will vary on load demand. As an example, at idle both the pumps may be running at approx. 40% duty cycle and at part load they may be at 55% and then ramping up to full load at 80% duty cycle.

This cycle will continue as load increases and decreases while keeping fuel pressure at a constant pre-programmed 400 kPa.

#### **KPM2200 - Primary and Secondary Module**

On every start-up, the secondary module pump/s are primed for 10 seconds only. This ensures the circuit is tested and that the secondary module pump/s are always ready and primed when required for high load operation.

Primary module fuel pumps are always running and duty cycle input will vary on load demand. As an example, at idle both the pumps may be running at approx. 40% duty cycle and at part load they may be at 55%.

When the primary module reaches 90% duty cycle, the fuel controller will then turn on a *duty cycle signal* to the secondary module fuel pump and continue to ramp duty cycle up or down accordingly as required.

When load decreases and the controller sees the primary module requiring a duty cycle of only 80% it will then slowly ramp down the *duty cycle signal* to the secondary module and eventually turn it off. This cycle will continue as load increases and decreases while keeping fuel pressure at a constant pre-programmed 400 kPa.



## Important

This fuel system is engineered to operate perfectly as a complete system, when used with all components as supplied only by KPM Fuel Systems.

Depending on the level of KPM Fuel System you have purchased, included in the kit will be the following;

- 1) KPM PWM Fuel System Controller - (for precise electronic control over fuel module operation)
  - 2) KPM Plug and Play EMI safe wiring kit (for correct, reliable and safe current supply)
  - 3) Early Model Commodore Fuel Pressure Sensor kit (2006-2009 models only).
- KPM Fuel Systems will take NO responsibility for the operation of this fuelsystem if any of the components listed are not utilised with this package.
  - KPM Fuel Systems will take NO responsibility for the operation of this fuel system if any of the components listed are replaced with a non-KPM approved component.

## Dismantle Vehicle for Fitment

- 1) Remove the passenger seat from the cabin.
- 2) Access the battery behind the passenger seat trimming.
- 3) Remove the utility tub liner from the vehicle to access the wiring at the cabin grommet and the fuel pump module wiring under the RH false floor cavity area.



- If the vehicle has already been fitted with a KPM Fuel Module, you can disconnect the wiring at the fuel module by unplugging the grey Anderson connectors.
  - Proceed to remove and discard the rest of the previous KPM wiring and relay that leads to the battery (this will be replaced with the new #Com4-U wiring supplied)
- If the vehicle is now being fitted with the KPM Fuel Module/s you will now have access to the large grommet/s on the RH floor area where the standard factory looms run through to the fuel tank.



At this point you will need to read the instruction section on the relevant [KPM Fuel Module Fitment](#).

## **PWM Fuel Controller Mounting**

- 1) Place your PWM controller in the correct position as pictured and while doing so use a marker pen to mark the 4 holes required for drilling.



- 2) Drill the 4 marked holes carefully with a 3.5mm drill bit and use the supplied screws to mount into position.
- 3) Be sure to mount the PWM controller small black earth wire/eyelet and screw down into one of the appropriate holes.



## PWM Controller Fuel Pressure Sensor Kit (Early Model 2006-2009 Models Only)

### Fuel Pressure Sensor Mounting

Depending on the level of KPM fuel system you have or are fitting, the Bosch fuel pressure sensor needs to be mounted in one of 2 different locations.

#### **Location 1 - 1500HP Single Fuel Module Systems**

The fuel pressure sensor is mounted undercar on the vehicle chassis rail next to the RHF of the fuel tank. KPM supply an auxiliary fuel hose #KPMFHCOM5 that connects direct to your KPM1500 fuel module and routes down next to the RHS of the fuel tank.

[The fuel tank needs to be removed to access the fuel module.](#)

- 1) Remove and discard the standard nylon fuel supply pipe that runs from the primary fuel module outlet down the side of the tank.



# **KPM** FUEL SYSTEMS

- 2) Replace the nylon fuel line with the new #KPMFHCOM5 'Y' piece fuel line section and fit securely to the tank.
- 3) Mount the fuel pressure sensor bracket supplied to the chassis rail area next to the RHF of the fuel tank as pictured.



- 4) Remove the utility tub liner from the vehicle to access the wiring at the cabin floor grommet and locate the fuel pump module wiring under the RH false floor cavity.
- 5) Feed the fuel pressure sensor wiring section #Com9 through the floor grommet, ensuring you have left plenty of length to reach the fuel pressure sensor.
- 6) Under car- Neatly secure the wiring from the grommet area to the fuel sensor, ready for fitment of the fuel tank.
- 7) In car- Neatly route the sensor wiring along the false floor cavity towards the PWM and connect to the PWM 4-Pin connector marked 'Fuel Pressure Sensor'.
- 8) Refit the fuel tank as per manufacturer's instructions.
- 9) Fit the #KPMFHCOM5 fuel supply line quick release connector to the steel fuel supply pipe.
- 10) Fit the #KPMFHCOM5 fuel sensor line quick release connector to the Bosch Fuel Pressure Sensor fitting and fit the sensor to the mount.



- 11) Fit the fuel sensor #Com9 wiring connector into the fuel pressure sensor.
- 12) Be sure to check the fuel pressure sensor for any leaks upon first start up.

## **Location 2 - 2200HP Dual fuel module systems**

Due to the 2200HP system requiring a high flow fuel line and fuel filter kit, we have incorporated a provision in the fuel filter housing to accept the fuel pressure sensor.

The KPM high flow fuel hose and filter kit must be fitted and is supplied as part of the KPM2200HP Fuel System.

- 1) Ensure the fuel line has no fuel pressure.
- 2) Remove and discard the blanking plug from the KPM fuel filter canister.
- 3) Lightly screw the Bosch Fuel Pressure Sensor into the fuel filter canister provision.
- 4) Ensure that the pressure sensor angles slightly towards the floor pan to give plenty of provision for the sensor electrical connector plug.
- 5) Remove the utility tub liner from the vehicle to access the wiring at the cabin floor grommet fuel pump module wiring under the RH false floor cavity.

- 6) Feed the fuel pressure sensor wiring section #Com9 through the floor grommet ensuring you have left plenty of length to reach the fuel pressure sensor.
- 7) Plug the #Com9 connector into the fuel pressure sensor and ensure that the sensor and connector are at a safe angle that will not be damaged.
- 8) Carefully tighten the fuel pressure sensor into the fuel canister.
- 9) Neatly secure the wiring under car from the fuel sensor to the grommet area, ready for fitment of the fuel tank.
- 10) In car- Neatly route the sensor wiring along the false floor cavity towards the PWM, and connect to the PWM 4-Pin connector marked 'Fuel Pressure Sensor'.
- 11) Refit the fuel tank as per manufacturer's instructions.
- 12) Be sure to check the fuel pressure sensor for any leaks upon first start up.

## **PWM Fuel Controller Wiring**

- 1) Depending on the level of KPM Fuel system you have installed – either KPM1500 HP or KPM2200 you will need to follow the appropriate wiring diagram below.
- 2) All Anderson wiring connectors are colour coded to ensure correct connection orientation as per wiring diagram.
- 3) Route the supplied wiring as per your specific fuel kit and as per appropriate wiring diagram and pictures listed below.

**\*Note – The PWM Fuel controller wiring is made with a stainless-steel shielding incorporated. This is to prevent EMI (electro-magnetic interference) from disrupting other vehicle systems and control modules. It is very important that the grounding wire connectors that link together every section of the supplied wiring are connected as per wiring diagram.**

## 1500 HP KPM FUEL SYSTEM

VE Commodore 2006-09  
PWM and Wiring Schematics

Ute Only

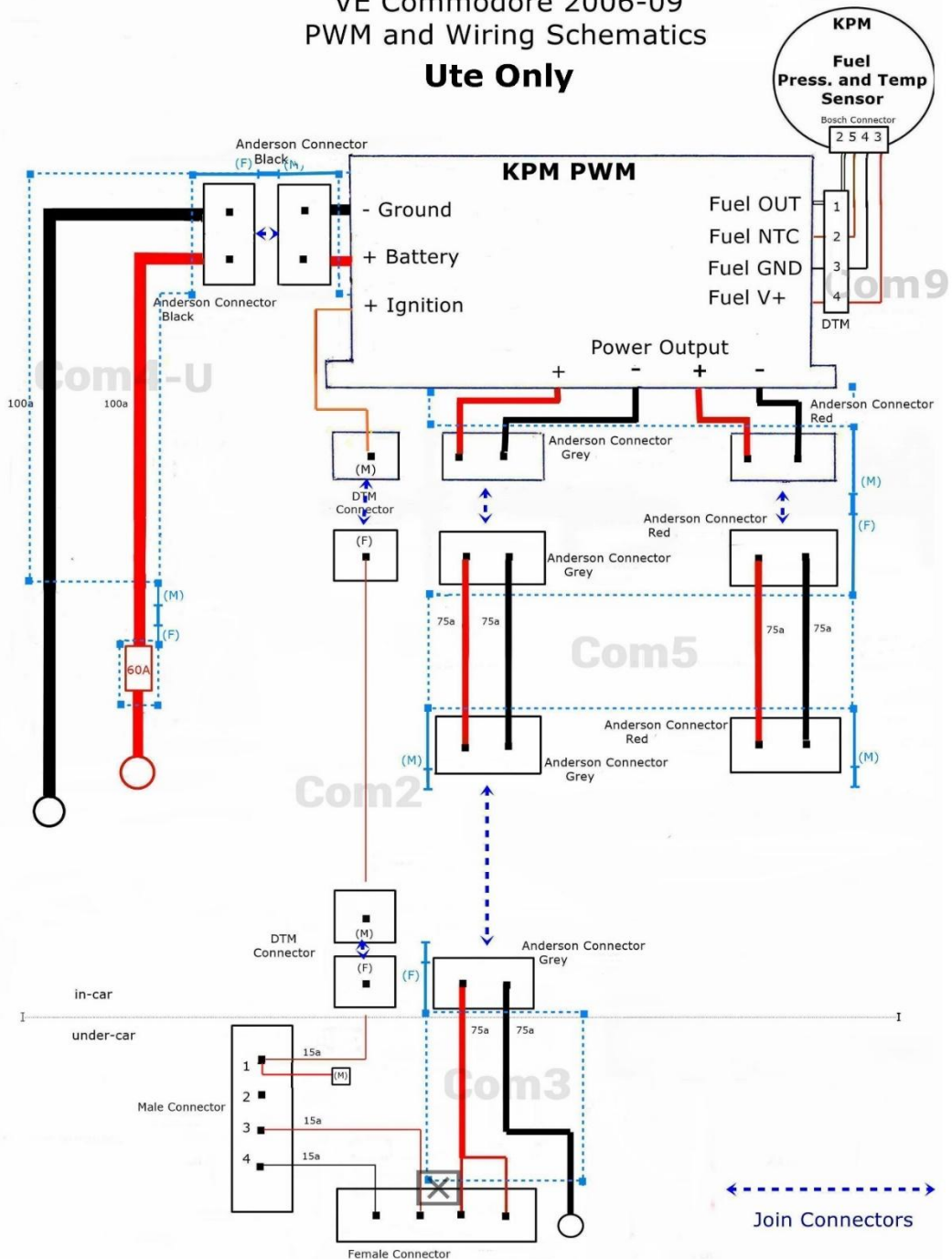

## 2200 HP KPM FUEL SYSTEM

VE Commodore 2006-09  
 PWM and Wiring Schematics  
**Ute Only**

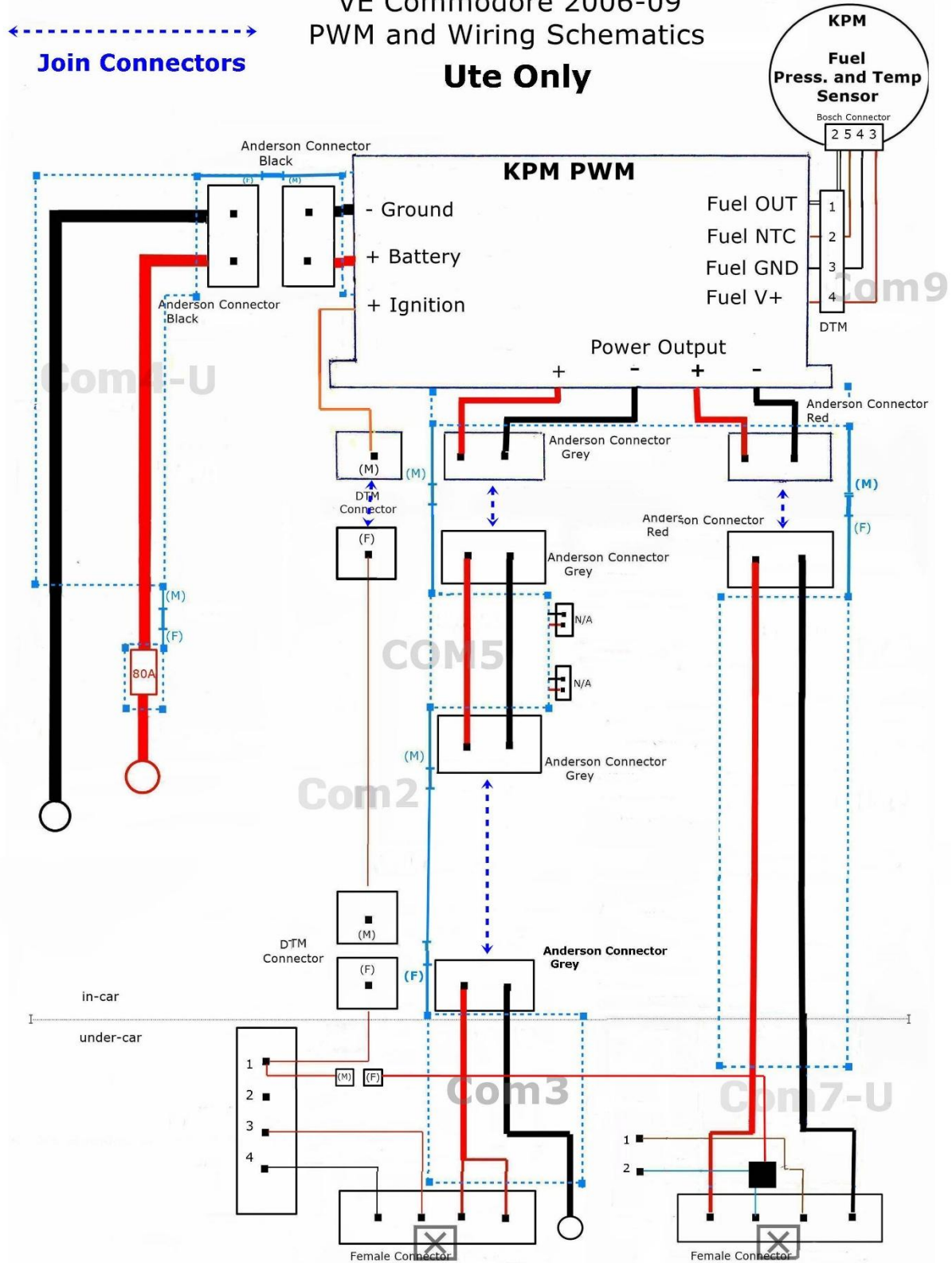

## Wire and cable routing

- 1) Depending on the level of fuel system you have installed, you will have either one or two separate fuel modules that require wiring to the battery and PWM Fuel controller.
- 2) The only difference between a single fuel module wiring (Com5) and a dual fuel module wiring kit is that the dual module wiring kit will contain an extra cable (Com8-U) that runs from the second fuel module to the PWM.



- 3) The pictures below will best show the routing for the cables and wires for all fuel systems.
- 4) Run the #COM4-U wiring loom from the battery, up behind the rear cabin trim, through the cabin access grommet towards the PWM.



- 5) Use a wire/tube trace to feed the #COM5 wiring loom from the Primary fuel module wiring, under the false floor liner towards the PWM.



- 6) Mount the supplied the fuse box securely on an appropriate surface near the battery and secure the loom.





- 7) Neatly and securely fasten all cables as pictured with cable ties.

## **Start Up & Checks.**

- 1) When you are satisfied your KPM Fuel System Controller is fully installed, you are now ready to start your vehicle.
- 2) On first start check the fuel pressure sensor and fittings for any leaks.
- 3) Run the car as normal.
- 4) On one face end of your KPM Fuel System Controller you should see a green LED flashing approximately once per second. This means that all systems are working normally.

Note\* If your LED is not flashing green approximately once per second or is flashing any other colour, you may have a system problem. Please contact KPM Fuel Systems.

## **Refit interior**

- 1) You can now refit your passenger seat.
- 2) You can refit your utility tub liner.

Congratulations, you have successfully fit the KPM PWM Fuel System Controller.

## **IMPORTANT INFORMATION**

KPM strongly recommends that you have your engine tune checked by a professional tuning workshop!

Depending on the previous fuel system your vehicle has been tuned to, your car may run differently with the new KPM Fuel System pressure and extra supply.

This can cause rich or lean fuel mixtures and possibly be detrimental to your engine!

It is your responsibility to have your vehicle checked and/or re-tuned by specialist methods to ensure correct fuelling and engine safety and reliability.

It is your responsibility to have your vehicle checked and/or re-tuned by specialist methods to ensure any fault codes in the vehicles electronic management system/s are corrected.